



WORKS PERFORMANCE PRODUCTS, INC.
 21045 Osborne St., Canoga Park, CA 91304
 818.701.1010 fax 818.701.9043
 www.worksperformance.com

Small Body Shock with Reservoir Overhaul Service Sheet

SBREZSVC--02-07-2007

RESERVOIR SHOCK NOMENCLATURE

1. Nitrogen fill valve
2. Reservoir(see inset)
3. Braided Steel Hose*
4. Angle fitting***
5. Eye (see note)
6. Bushing**
7. Body
8. Crossover Spacer
9. Threaded Pre-load***
10. Body Snap Ring
11. Eye(see note)
12. Lower Spring Retainer
13. Bumper Washer
14. Bumper
15. Shaft
16. Seal Holder
17. Inside Spacer***
18. Piston Assy

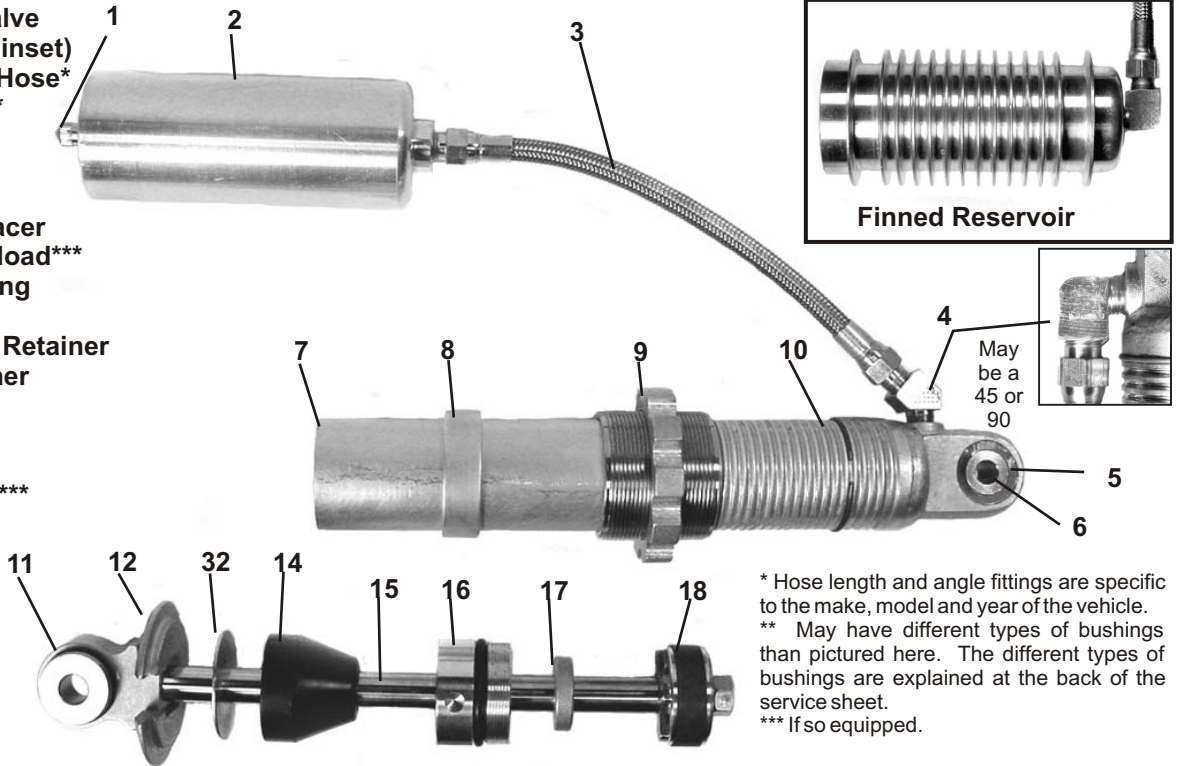

Note: May have a Clevis in place of the eye, check the back of this service sheet for descriptions.

* Hose length and angle fittings are specific to the make, model and year of the vehicle.
 ** May have different types of bushings than pictured here. The different types of bushings are explained at the back of the service sheet.
 *** If so equipped.

CAUTION: These shocks are pressurized to 250 psi. with nitrogen. This pressure is not an adjustable feature of the shock. Unless there is a leak, the shock would not normally lose pressure. It is imperative that the gas be safely released from the shock before dismantling the shock or reservoir assembly.

BODY DISASSEMBLY

1. Clamp the shock in a vise at the shock eye only--not on the tube. In some cases, the spring retainer can be removed by hand. Otherwise, a spring compressor will have to be used.
2. On multi-spring shocks, the loose ring (or rings) called crossover spacers are on the body inside the short spring. They determine the point at which the spring set transitions from soft to stiff. Put them back in the same place, as they vary by thickness. On triple-rate springs, make sure that the same crossovers go inside the same springs.
3. Release the pressure from the reservoir. If the bladder has ruptured oil may also come out. Caution: These shocks are pressurized to 250 psi. with nitrogen. Point the reservoir away from your face when depressurizing. (Shock oil can be recycled along with used motor oil.)
4. Seal head spanner wrench (available from Works) is used to unscrew the seal head. Threads are right hand. It may take a good deal of force to break it loose.

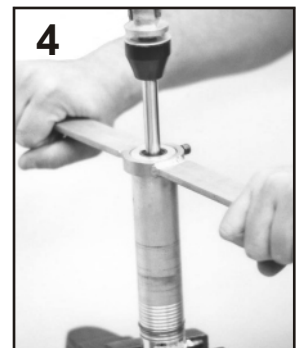
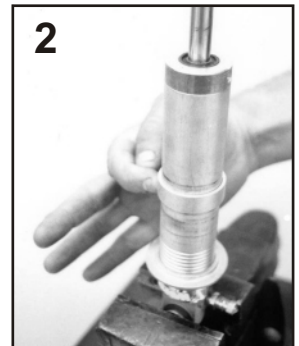
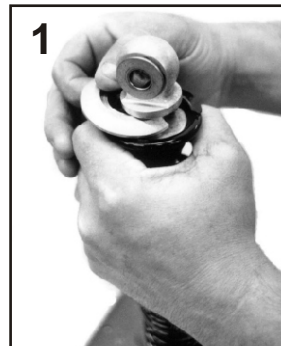

Continued on next page

5a,b. Remove the shaft assembly from the body. Inspect the shaft for pitting, scratches or other deep grooving. Replace if necessary.

Note: If the shaft is marred, then it should be replaced. New seals will not seal a damaged shaft. When ordering a shaft, measure the full length of the shaft from end to end. Two types of shafts were used in these shocks. The first is the "standard shaft, which has 3/8-16 threads at both ends. The other shaft is the "Magna" shaft, which has 3/8-16 threads on one end and 5/16-24 threads on the other. The older shafts with 3/8-inch threads on each end are no longer available. Speak to a Works technician for the correct conversion shaft. A new conversion shaft can be used with the threaded piston.

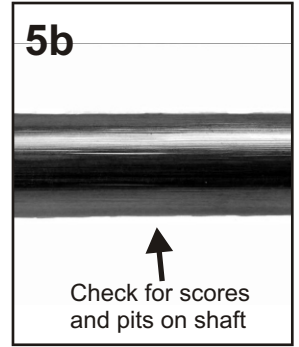

6. Clamp the eye only--do not clamp the shaft. Remove the nut that secures the damping piston on the shaft.

Note: On many older shocks, the piston is threaded and is screwed on to the shaft. The piston can be removed by putting a wrench on the flats of the star and unscrewing. It is a right hand thread. On these shafts, the long threaded end of the shaft goes in the piston. If the shaft must be replaced, it will be converted to the late model shaft design (see above).

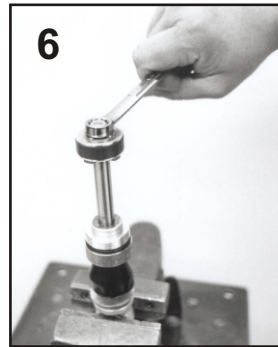

7. Carefully remove the piston assembly. The damping components inside, which are specific to each hole in the piston, can fall out and be easily mixed up.

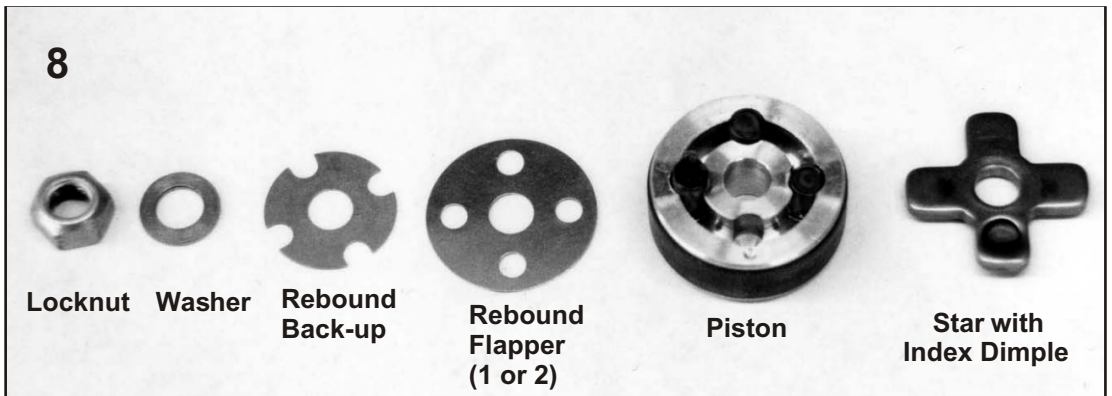

8. The piston stack as it fits on the shaft from right to left: star; piston; flapper (1 or 2 each of 1 or 2 thicknesses); back up; piston washer; and piston lock nut. The dimple in the star indexes into hole with no ball or spring. Rebound flappers (use and quantity and thickness varies by shock model) have a slight cone shape. The concave side should go down against the piston face. While the back up is always on the outside of the stack next to the piston washer, the flappers start with the thickest next to the piston out to the thinnest. (They may all be the same thickness.) If the piston has a floating ball, the dimple in the star fits over that hole and ball.

9. Each valve spring (two on older shocks, three on later shocks) should be removed individually and identified so that they will go back on top of the ball in the same hole. The balls are all the same, but the springs have different rates and have specific relationships to each hole size under the ball. Most pistons will have a dimple on the piston face that indicates the compression and rebound "through hole," or free bleed. This pocket is shallower than the other pockets, and is not equipped with a ball and spring.

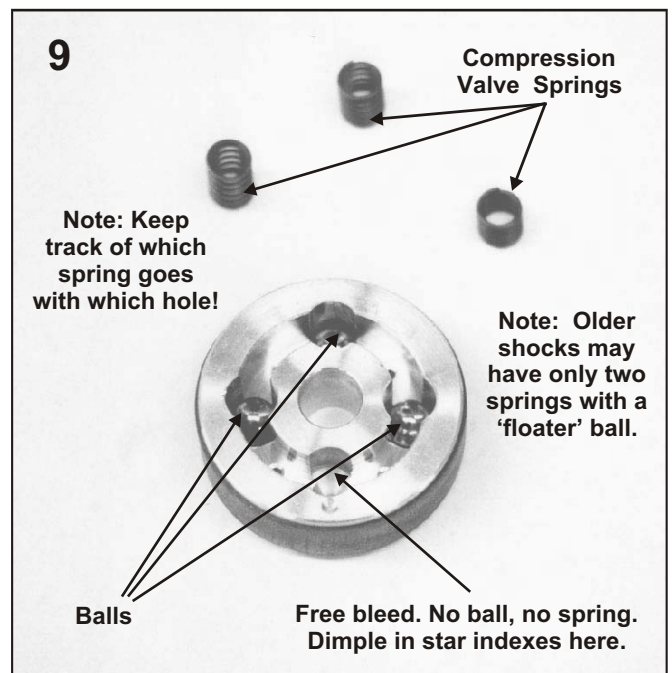

10. On many shocks, a spacer is used inside to adjust the eye-to-eye length. It fits between the seal head and the piston.

Sometimes the shoulder of the shaft where the piston is installed (see arrow) will flare out slightly to a burr. Carefully use a light file to smooth that spot, so that the seals are not damaged during assembly. Do not nick or scratch the sliding surface of the shaft, or the shock will leak right away.



Note: If neither the shaft nor eye (or clevis) needs to be replaced, leave these components assembled. If the shaft needs to be replaced, clamp the eye or clevis in the vise and unscrew the shaft from the eye. Since the shaft is not serviceable, it can be removed with vise grips. It is helpful to have a heat gun to heat the eye to break the bond of the thread adhesive. On the other hand, if the shaft is to be saved and a new eye or clevis installed, then you will need the shaft clamp set as shown in the tools section of the overhaul guidelines. In most cases, you will need a hydraulic press to clamp the shaft sufficiently to remove the eye. Sometimes the clamp will work in a large vise.

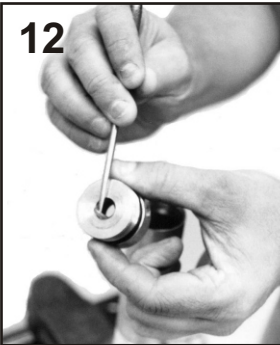

11. Put the seal head back into the body. Pry out the outer seal with an open-end wrench (5/8-inch or 17mm works great.) Avoid scratching the inner surface of the seal bore or shaft bore.

12. With a plastic or aluminum pick, remove the inner O-ring seal. This is the main pressure seal, so take care to avoid scratching the groove. The outer O-ring should be removed with the same care.

13. The outer seal can be pressed in place with either an arbor press or between the jaws of the vise. Lightly grease the O-rings and reinstall them.

Important Note: Make sure that the balls are visible thru the valve holes.

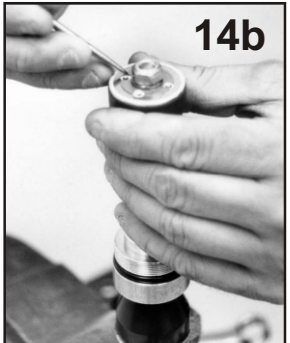
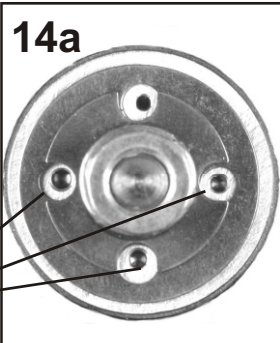

SHAFT ASSEMBLY

14a,b. When installing the piston assembly and the shaft washer and nut, position the rebound flappers so that the balls are visible through the valve holes. This is critical to proper performance. Look for the balls.

15. Hold the flappers in position and tighten the shaft nut to 16 ft. Lbs of torque. Check to see that the balls are visible through the flapper holes.

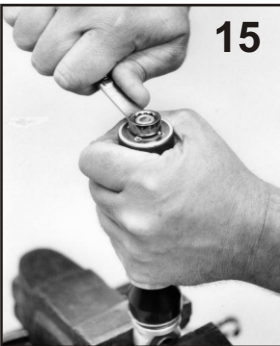

HOSES, FITTINGS AND RESERVOIRS

Note: It is unnecessary to remove the hose or fittings during an oil change service or seal replacement unless there is a damaged fitting or hose. If the hose or fittings are removed, mark the hose, fittings, reservoir and shock eye as to the relationship of each before disassembling. This way they can be re-assembled in the correct manner. See figure 16.

Note: To avoid undue stress on the fittings, when removing a hose from the fitting, hold the fitting with a wrench..

17a, b. Inspect hose for frayed edges, kinking, or leaks. If damaged or questionable replace the hose. If the stainless steel sheath is frayed, it can cause the hose to rupture when pressurized.

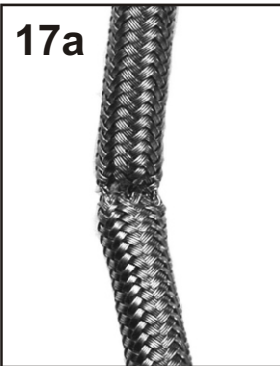

RESERVOIR DISASSEMBLY

18 & 19. Press in the bladder end cap past the snap clip groove. Remove the snap clip and grasp the hex part of the valve lightly with vice grips and pull it out of the reservoir body. Inspect the o-rings for cracking or wear.

20. Inspect the bladder for cracking and holes. Squeeze the bladder at the end. If it is cracked or split, it will show then. If the bladder has oil inside it, this usually means that it is cracked. Bladders are most often damaged when a shock leaks oil from its seals or hoses, because the bladder expands to fill the void left by the missing oil. It tries to go down the 3/16" hole at the end of the reservoir and pops. If damaged or questionable replace.

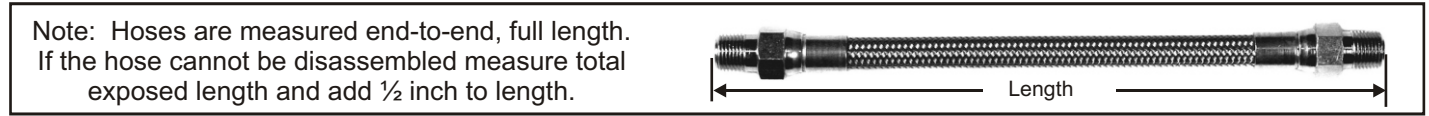
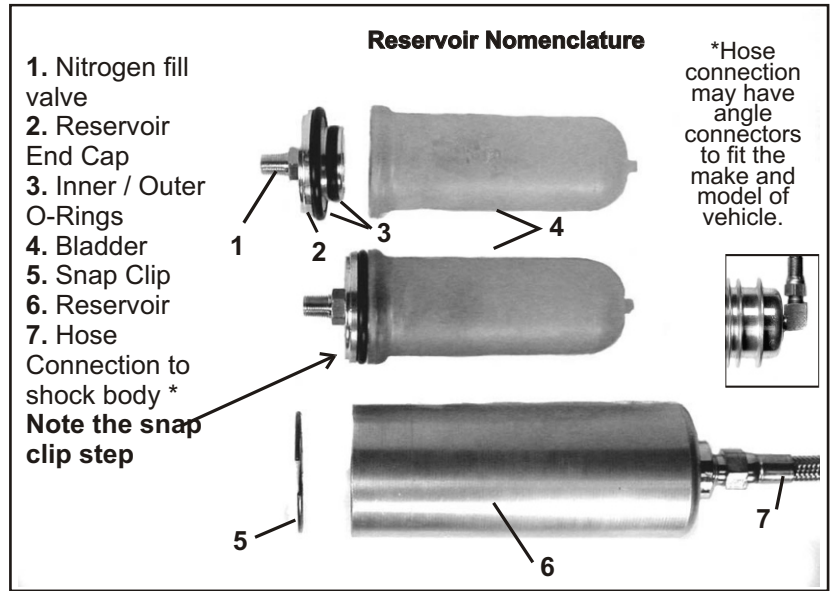

Remember to orient the reservoir, hoses and fittings to the body as originally built. If any hoses or fittings have to be replaced make sure to apply Teflon tape, winding it in a clockwise direction as seen in figure 21.

22. Be cautious when installing hoses and / or fittings as they can cross thread easily. The hose and fittings should be snug. Avoid over-tightening as the fittings can be stressed and leak.

BLADDER AND CAP DESIGNS

Two designs of bladder caps have been used in the reservoirs. Early bladders were cast with a groove on the outside for a large O-ring. This was replaced with an integral O-ring on later bladders. The bladder caps were different as well to fit the bladder. Original bladders and caps are not available, but the latest assemblies will retrofit perfectly. Also, the last bladder cap design utilizes a filling valve that is sealed with an O-ring. This valve fits flush against the top of the cap (see figure 23). Earlier models used a tapered pipe thread valve. It has one or more threads that show below the hex (see figure 24). Removing the valve from the early cap is very difficult because of a special clamp that is necessary to hold the cap to remove the valve. If you must replace an early pipe thread valve, it is advisable to replace the cap and valve with the newer style.

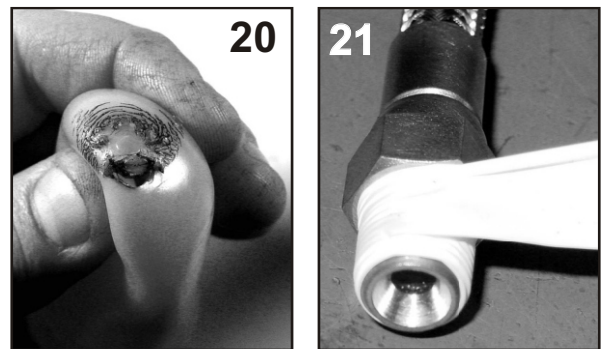
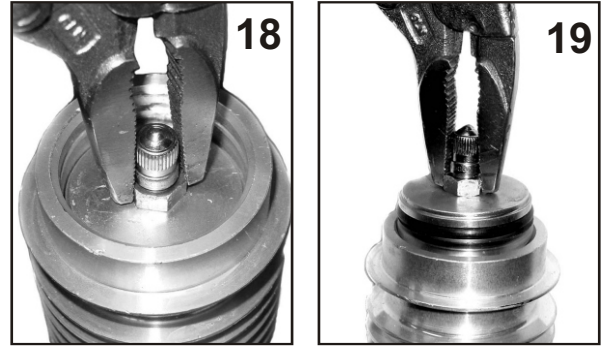

BLADDER ASSEMBLY

Make sure that the bladder is fully open. If it is "sunk in," unscrew the valve core and let the bladder expand. Re-install the valve core. If the bladder is "permanently sunk in," use a bicycle pump to put a very small amount of air in the bladder, just until the sides are straight. **DO NOT USE COMPRESSED AIR AS THIS WILL BLOW THE BLADDER OFF THE CAP.**

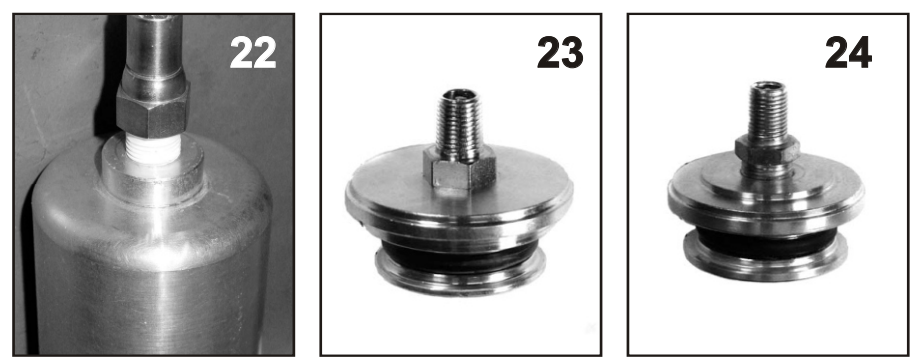

FILLING THE SHOCK AND RESERVOIR WITH OIL

Note: The oil level is critical to proper performance. Ideally the goal is to eliminate any trapped air in the shock body or in the reservoir. Trapped air can cause a loss of damping, and if it is excessive, can cause the bladder to rupture.

Reassemble the hose and fittings to the body and reservoir (if removed for replacement). The shock should be held in a vise by the eye only, with the reservoir to the side over a drain pan.

25. The shock is filled from the reservoir through the hose and into the shock body. Pour enough oil into the open reservoir so that the trapped air in the line bubbles up through the shock body, and that the reservoir and body are about one-third full. Hold the reservoir at the same height as the body to achieve equal levels.

26. Insert the bladder assembly slowly into the reservoir so that the oil level rises. Raise or lower the reservoir (in relation to the shock body) to position the bladder assembly so that oil flows past the O-ring just as the O-ring is inserted into the reservoir. This will ensure that there will be no trapped air in the reservoir. (The excess oil will overflow into the drain pan.) Push the bladder assembly down inside the reservoir far enough to install the retaining clip.

27a & b. After installing the clip, pull the reservoir end cap out fully to make sure that the clip is fully engaged with the groove. Grasp the fill valves by the flats and pull the end cap out to fully engage the clip. Let the reservoir dangle by the hose to its lowest point. If there are any residual air bubbles, they can now escape through the line and up into the body.

28. Regardless of shaft diameter, the oil level measurement for shocks with reservoirs is 1/2-inch. Bend a piece of wire (coat hanger or welding rod) into a dipstick.

29. Fill the shock to about 1-inch from the top of the body. Slowly insert the shaft assembly with the inside spacer (if so equipped) on top of the piston until oil comes up through the piston. With the dipstick, measure to the top of the piston (or inside spacer if so equipped). Push the shaft assembly in or pull it out as necessary to get the top of the piston (or inside spacer) to 1/2-inch from the top of the body. The oil level should be even with the top of the piston (or inside spacer). Remove or add oil to attain this level. (If oil sucks back down inside when the shaft assembly is pulled up to the half-inch measurement, remove the shaft assembly and add a little oil, and then re-insert.)

30. Carefully hold the shaft assembly in place and push the seal holder down into the body, and thread it in by hand until the O-ring is inside the top of the body. Tighten the seal holder snugly with the wrench. Snug plus one tug is tight enough.

PRESSURIZING THE SHOCK WITH NITROGEN

Caution: Make sure that the snap clip is fully engaged with the groove BEFORE pressurizing the reservoir or serious injury could result! See figures 27a and 28b.

31. Screw the filling manifold on the valve and bring the pressure up to 250-psi dry nitrogen. Screw the T-handle down to depress the valve core to fill the bladder with nitrogen. With the manifold still at 250 psi, unscrew the T-handle to close the valve core to capture the nitrogen in the bladder. If the pressure is released in the manifold before the valve in the reservoir is closed the shock will have to be refilled with nitrogen.

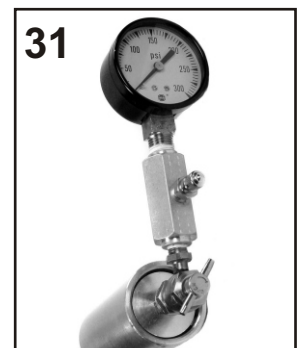
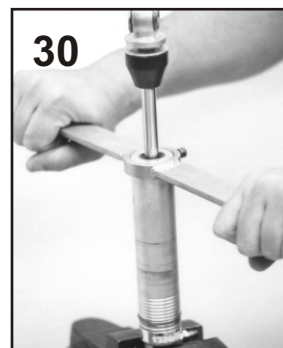
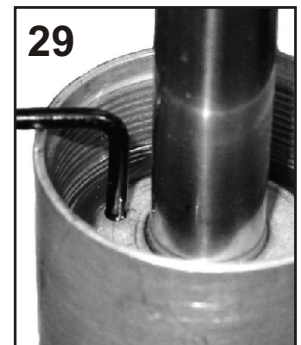
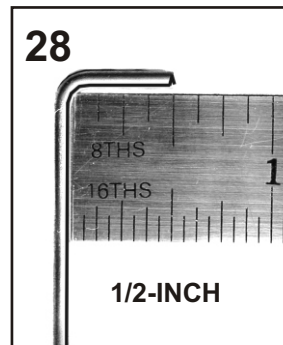

Eye, Clevis and Bushing Descriptions

33. Clevis, this is used on some installations. If you are replacing the clevis, note the size of the holes on each side, the depth of the clevis from the center of the holes to the “crotch”, and the width of the clevis.

Note: Various bushing sets are used in the shock eyes (eyelets). When replacing these bushing sets measure the width and inside diameter of the steel inserts.

Urethane Type (Figs. 34a, b & c). This is the most common type consisting of a urethane outer sleeve and a straight or flanged steel insert. The spacer outside diameter is 5/8-inch. These are normally removable by hand. In some cases, wide steel spacers have aluminum side spacers on one or both sides of the eye (Fig. 34c).

“Igus” Type (Figs 35a & b) This set consists of an inner thermoplastic sleeve bearing that is pressed into the eye with an arbor press. One long (Fig. 35a) or two flanged steel inserts (Fig. 35b) slide inside the bearing. The flange outside diameter is 1-inch. O-rings are used depending on the width of the flange insert--bushings without the step do not use O-rings. These bearings are designed to be used without lubrication. Specifically do not use a spray lube (chain lube for instance) because the carrier can cause the bearing to swell up and seize on the inserts.

Spherical Type (Figs. 36a & b). This consists of a spherical bearing (also referred to as a “Heim” bearing) that is pressed into the eye with a hydraulic press. For all mounting bolt sizes 12mm and smaller, steel inserts are pressed into the bearing from each side. For 1/2-inch bolts, the sleeves are loose on the sides. These steel inserts are 3/4” outside diameter. O-rings are used to exclude dirt and moisture from the bearing. These bearings need to be greased occasionally. Peel the O-rings off and lube the bearing. Then install the O-rings to capture the grease.

